

Future Internet Winter Camp 2009 (FIWC 2009)

# PlanetLab에서의 Indirection Multicast 구현

2008-02-24

Hoon-gyu Choi, Soyoung Park, Hojin Lee, Taewan You,  
Taekyoung Kwon, Yanghee Choi

**mmLab**

Multimedia and Mobile communications Laboratory

# Contents

---

- ❑ Introduction
- ❑ Environments
- ❑ Methods
- ❑ Lessons

# PlanetLab

---

- ❑ Global research network
  - ❑ Virtualized
  - ❑ Planet-scale
  - ❑ Application layer – good for **overlay network experiments**
  - ❑ <http://www.planet-lab.org>
  - ❑ Consists of 957 nodes at 476 sites

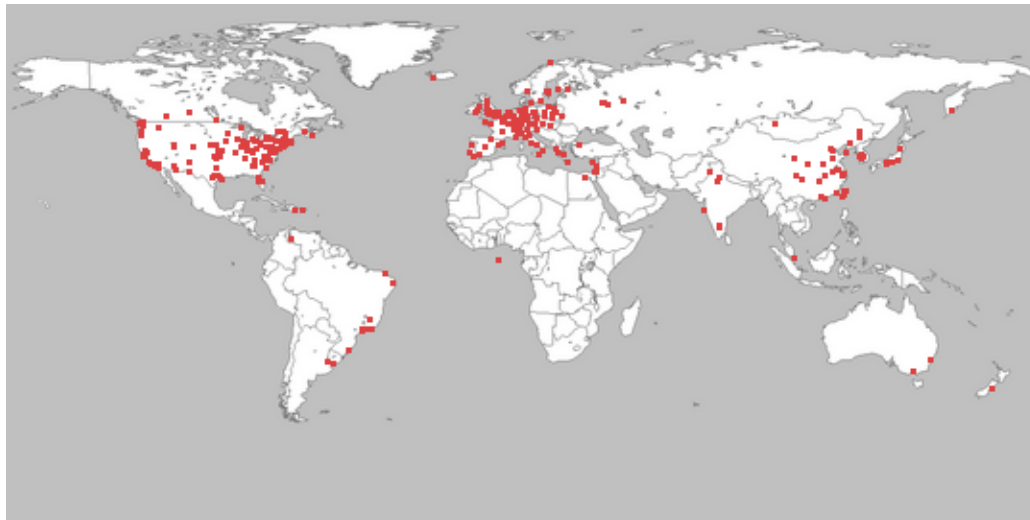

# Internet Indirection Infrastructure (i3)

- Overlay-based Architecture
- Realize a general communication abstraction
  - Multicast, Anycast, & Mobility

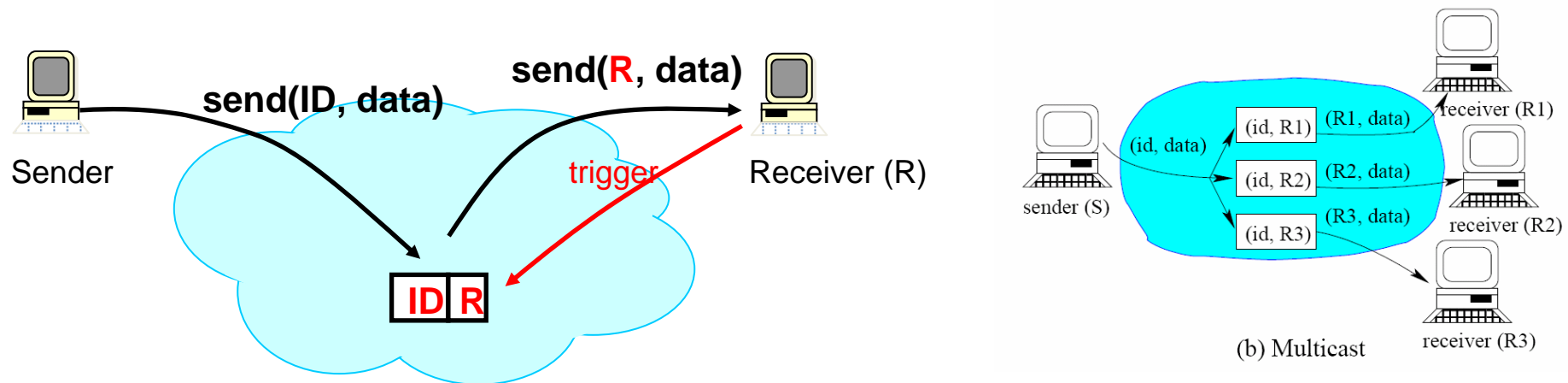

❖ Ion Stoica et. al. SIGCOMM 2002

# End-host Controlled Multicast (ECM)

- Hierarchical multicast tree construction
  - Scalable multicast in terms of group size
    - ◆ Branch and bound heuristics
    - ◆ Efficiency + flexibility
  - Unicast, multicast, anycast, service composition (middle box), security (due to i3)

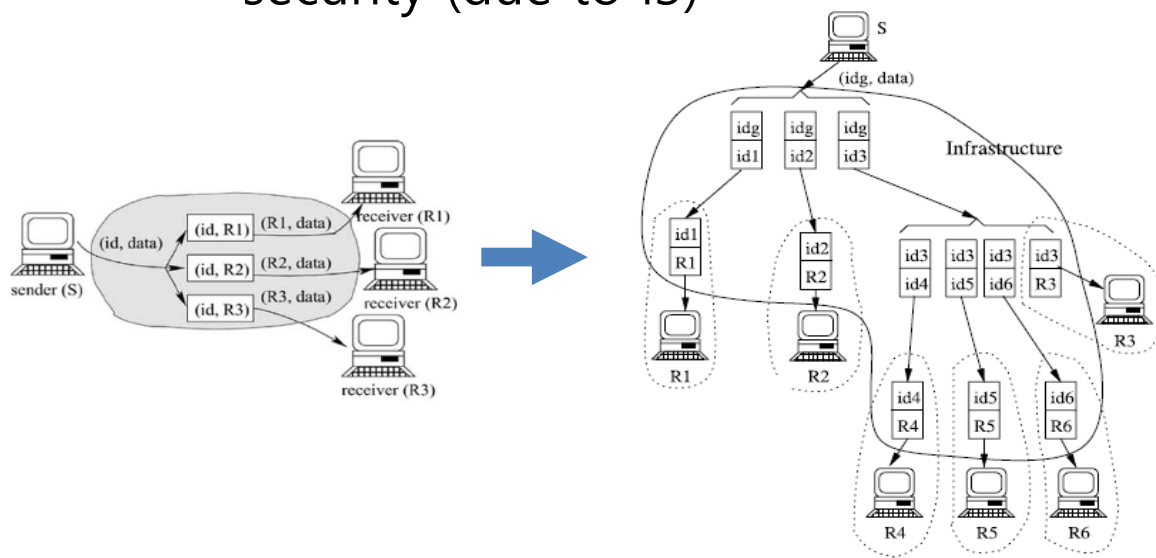

- ❖ Join in a top-down manner
- ❖ Out-degree bound
- ❖ Physical topology not considered

# Proximity-Aware Indirection Multicast (PAIM)

- Aggregation using physical proximity
  - Join unit: an individual node -> multiple nodes located near
    - ◆ Individual unicast to children -> aggregate transmission to the multiple nodes located near
    - ◆ Link stress, e2e delay enhanced
  
- Method
  - Introduce proximity id into random id
  - Avoid joining to parent directly and try to join to siblings near a joining node

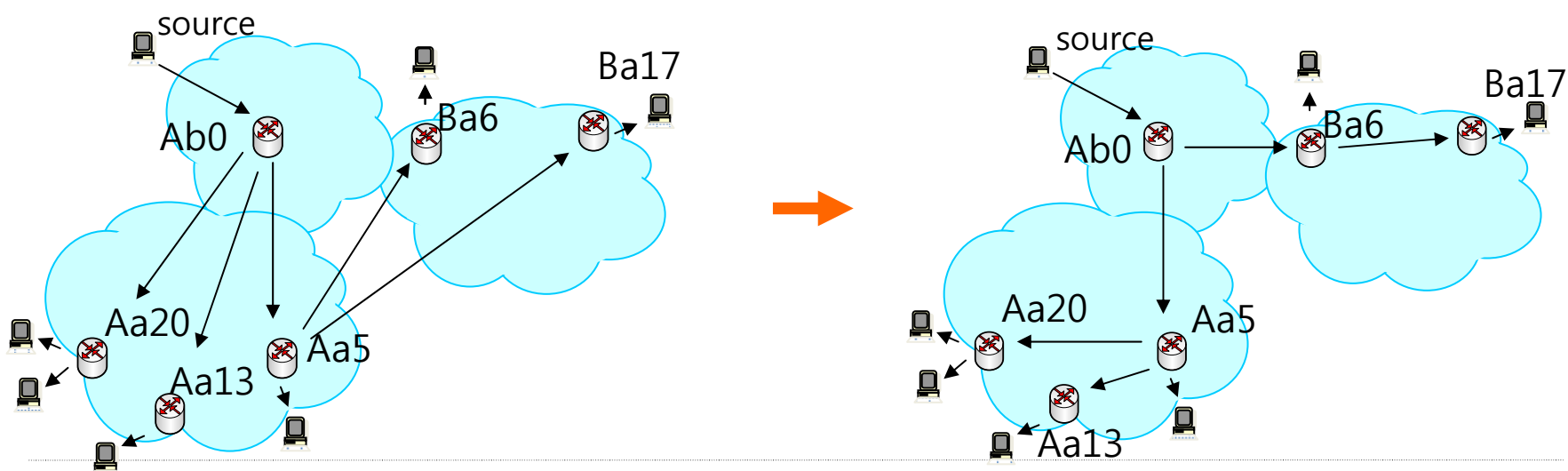

# Overview

---

- Implement 2 algorithms
  - ECM
    - ◆ by modifying Trigger Insertion part in i3
  - PAIM
    - ◆ by modifying ID Allocation and Trigger Insertion part in i3 and ECM
  
- Compare each other
  - Tree construction
  - End-to-End Delay
  - Streaming

# Environments

---

- ❑ Software
  - ❑ **OCALA**
  - ❑ Visualization Tool
  - ❑ VideoLAN media player
  
- ❑ Hardware (machine)
  - ❑ PlanetLab nodes
  - ❑ Three laptops
  - ❑ Two servers

# OCALE

- ❑ Overlay Convergence Architecture for Legacy Applications
  - ❑ Leverage the functionality of new architectures and overlays
  - ❑ i3 is already implemented in OCALE
  - ❑ <http://ocala.cs.berkeley.edu>

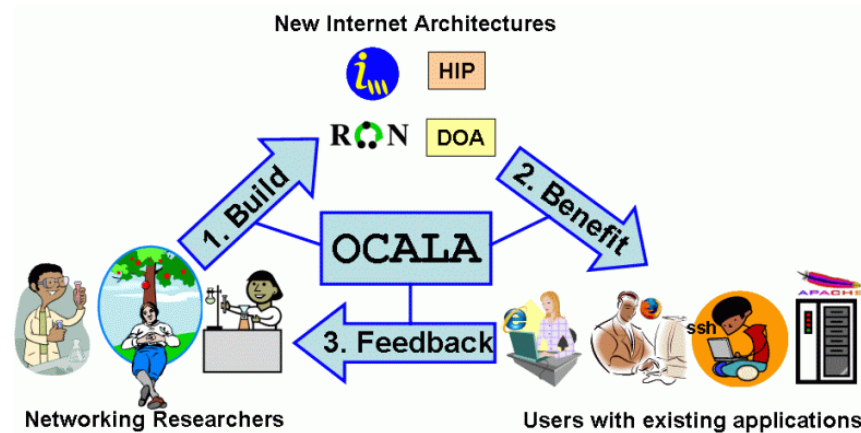

# OCALE Architecture

- Overlay Convergence (OC) Layer
  - Bridges legacy applications and overlays
  - Consist of two sub-layers
    - ◆ OC Independent (OC-I) Layer
      - Interacts with the overlays
    - ◆ OC dependent (OC-D) Layer
      - Interacts with the legacy applications

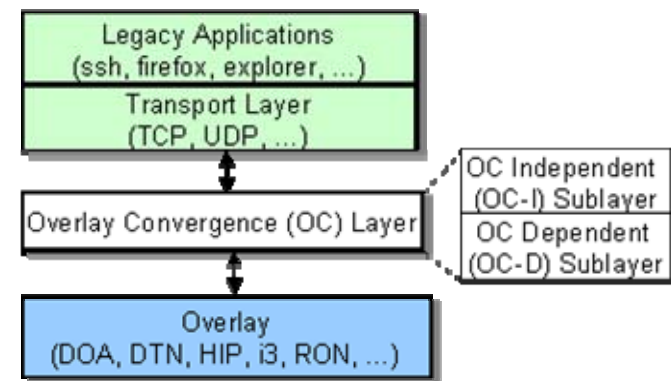
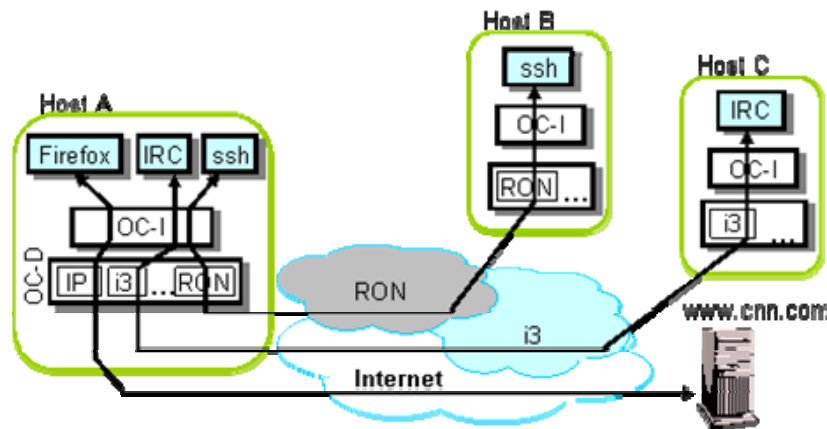

# OCALA Source tree

---

- Major modification or addition in OCALA
  - OCALA\_src\_2\_4a/i3
    - ◆ i3\_client/
      - some files are modified to implement ECM and PAIM
    - ◆ Examples/
      - recv\_private\_trigger.c is modified to demonstrate simple PAIM, ECM end-hosts

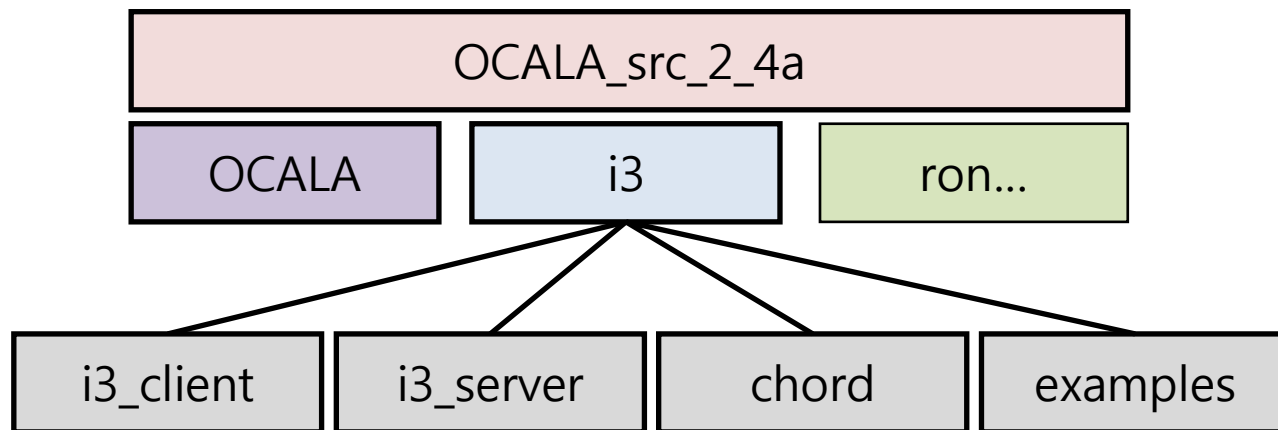

# Visualization Tools

---

- End-to-End delay
  - Use FusionChart
    - ◆ (<http://www.fusionchart.com>)
  - Java to make input data using XML
- Multicast tree
  - Python with Tkinter package

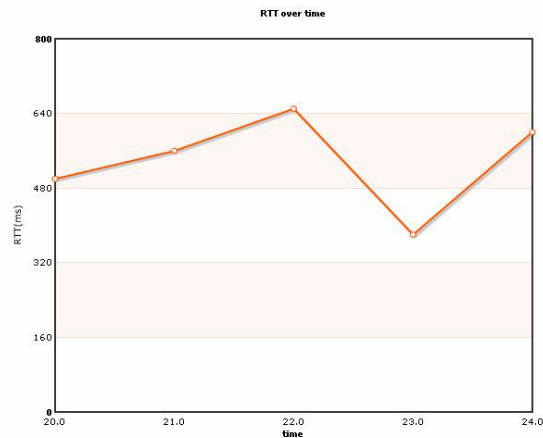

# VideoLAN media player

- ❑ Not only media player but also streaming server
- ❑ Use 0.8.6
  - ❑ <http://www.videolan.org/vlc/>

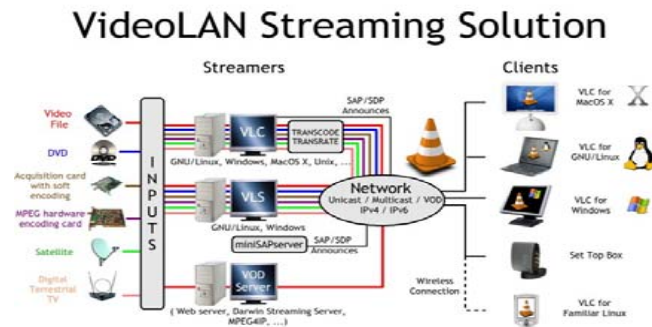

- ❑ A multicast source streams a video clips over OCALA
- ❑ Multicast receivers receives streaming over OCALA

# Methods - ECM

- Scalable tree construction
  - Scalable(=constrained) trigger insertion

- Related API
  - ID | R - cl\_create\_trigger()
  - ID1 | ID2 - cl\_create\_trigger\_id()
  - cl\_insert\_trigger()

- Trigger management
  - Triggers are internally stored in i3 Server
  - Using DB (MySQL 5.0)

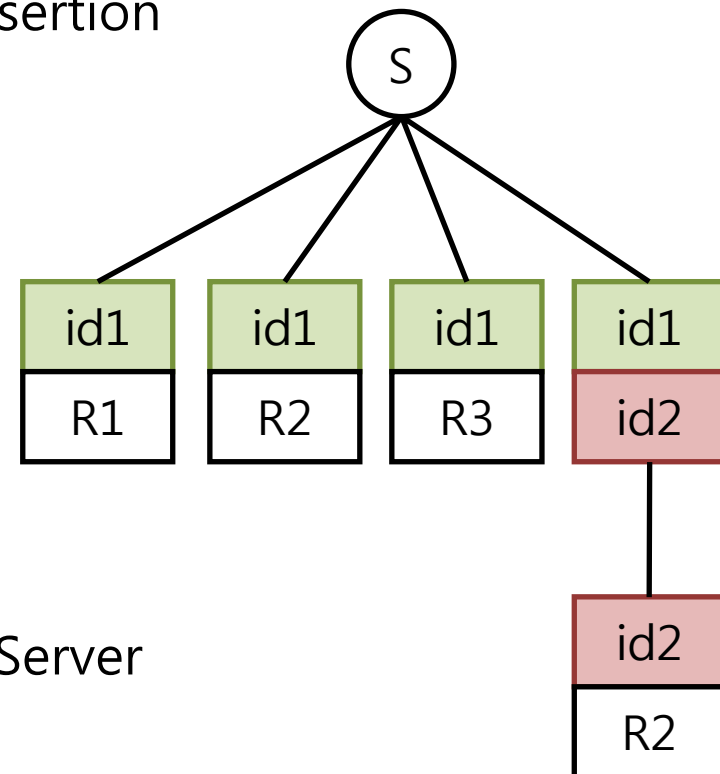

# Methods - PAIM

---

## □ Additional Function

### □ Physical Part (integer variable)

- ◆ Added to **i3 server**
- ◆ Embedded in **Client Context**
- ◆ 1 – Asia, 2 – Europe, 3 – Eastern America, ...

## □ Related API

- `cl_find_closest_ID()`
- `cl_get_closest_phy()`

# Testbed System

---

- ❑ Two laptops installed OCALA
  - ❑ Generic proxy (OC-I layer)
  - ❑ OC-D layer - i3
    - ◆ Send to i3 overlay networks
    - ◆ Receive from i3 overlay networks
  - ❑ Multicast Client
    - ◆ ECM (End-host controlled Multicast)
    - ◆ PAIM (Proximity-Aware Indirection Multicast)
  
- ❑ PlanetLab nodes
  1. Construct i3 overlay network
  2. Configure **two same/isolated topologies with two slices**
  3. Join with Multicast Client

# Lessons

## ❑ Node Selection

- ❑ Nodes are mainly distributed in Europe & North America
- ❑ Node state varies frequently



### CoMon PlanetLab Status (sort key: Name)

Part of the [CoDeeN](#) project  
 Updated Tue Feb 17 23:20:02 2009 EST (GMT -0500)  
[legend](#)  
 Summaries: By Node ([long](#), [short](#)) By Slice ([max](#), [average](#), [total](#), [site](#)) By Ports (Problems ([nodes](#), [slices](#)) Viz: [Auto](#) Resources (CPU, Mem, BW) Efficiency (CPU

#	Name	Resp Time	Node Type	Kern Ver	Date	CPU Speed	1 Min Load	Timer Max
	<a href="#">Address</a>	SSH Status	Boot State	FC Name	Drift	Busy CPU	5 Min Load	Timer Avg
	<a href="#">Location</a>	Uptime	Key OK			Sys CPU	Num Slices	Conn Max
		Last CoTop				Free CPU	Live Slices	Conn Avg
1	<a href="#">planet-lab1.itba.edu.ar</a> 190.227.163.142	0.55 S good 39.5 D 0.00 S		2.6.22.19 Werewolf	2-17-2009 23:20:02	2.0 49.0% 6.0% 98.8%	1.34 1.11 23 3	29.9 10.1 0.38 0.16
2	<a href="#">planet-lab2.itba.edu.ar</a> 190.227.163.141	0.56 S good 66.0 D 0.00 S		2.6.22.19 Werewolf	2-17-2009 23:20:02	2.0 24.0% 3.0% 99.8%	0.44 0.26 0 0	35.1 10.2 2.07 0.21

PlanetLab

- ▼ About
  - ▶ Consortium
  - Federation
  - History
  - Impact
  - Sponsors
  - Sites
  - Projects
- ▼ Status
  - Security Notice
- ▼ Support
  - Site Assistant
- ▼ Documentation
  - ▶ API
  - AUP
  - Bibliography
  - FAQ

### Home

#### Slice snummlab\_slice5 - Nodes

Select a site to add nodes from.

- Seoul National University - MMLAB
- Seoul National University - MMLAB**
- Silesian University of Technology, Insti
- Simon Fraser University
- Simula Research Laboratory
- Singapore Advanced Research and Education Network
- Space Monitoring Data Center SINP MSU
- SRI International
- Status
- Stanford University
- Stevens Institute of Technology
- Stony Brook University
- SUNY Binghamton
- Supélec, Campus de Rennes
- Swedish Institute of Computer Science
- Swiss Federal Institute of Technology Lausanne (EPFL)
- SwRI/UT San Antonio
- Technical University Ilmenau
- Technical University of Madrid
- Technion - Israel Institute of Technology
- Technische Universität Berlin

# Lessons

- Difficulty with proper comparison
  - Unexpected node failure can occur

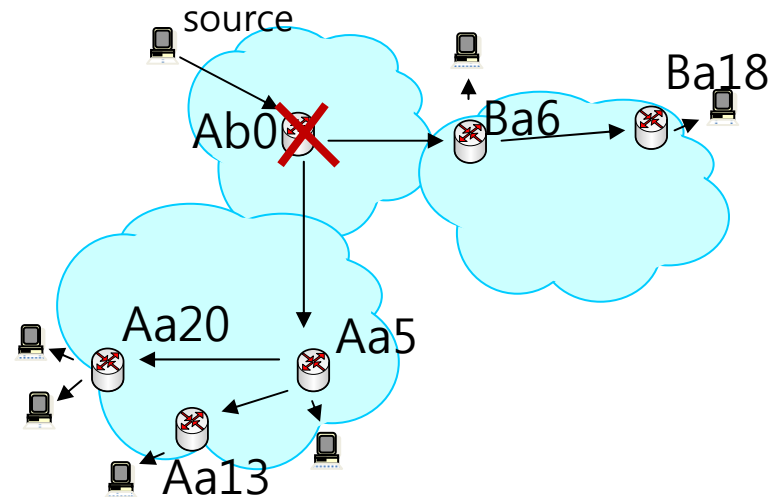
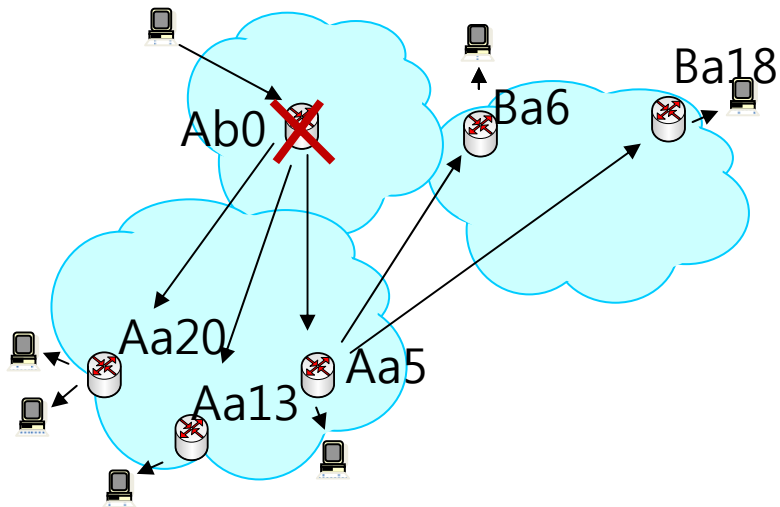

# Lessons

---

- ❑ Problems with node isolation
  - ❑ A node consists of many slices
  - ❑ A slice acts as a root
  - ❑ <IP address, Port number> based communication can cause a confliction between nodes

---

**Thank  
you!**